

# SoftParkingPOS

**HELP VERSION - 01.01.40      2005-05-23**

This help file serves the help manual to SoftWin version 3 and can be access via the program be selecting help.

## Index:

[Aim](#)

[General](#)

[Start-Up](#)

[Closing.](#)

[Configuration](#)

**EDITORS** Edit functions are described in the help file [SCS\\_Editor](#)

## [Set-up](#)

[PPOS](#)

[Set-up Editor](#)

[PC I/O Set-up](#)

[PPOS Cards](#)

[PPOS Colours](#)

[PPOS Controllers](#)

[PPOS Fare](#)

[PPOS Item groups](#)

[PPOS Items](#)

[PPOS Keyboard](#)

[PPOS PC](#)

[PPOS Printers](#)

[PPOS Province](#)

[PPOS Vender](#)

[Time groups](#)

[General set-up](#)

[Print](#)  
[Print preview](#)  
[Print set-up](#)  
[Log Fields](#)  
[Date and time properties](#)  
[SCS Client Links](#)

## [TOOLS](#)

[Logon/off](#)  
[Change password](#)  
[Menu Access](#)

## [VIEW](#)

## [WINDOW](#)

# 1 AIM

The aim and goal of this document is to serve as a general help manual for the use of the Softcon program SoftWin 3. More technical details are available in documents that describe the database functions, communication and installation specifics.

The document SoftWin3\_Spec lists the specifications of the program and those specifications must comply with this document and visa versa. Certain specifications may be duplicated here for completeness and clarity (e.g. priority criteria), but duplication should be limited where possible.

General development info about the program SCS\_PPOS is:

<b>Count of tasks:</b>	8 (plus Mux tasks and client request tasks).
<b>Program language:</b>	C++, IDL (Interface Definition Language).
<b>Technology:</b>	MFC, Multithreading, DAO, COM and RPC.
<b>Program architecture:</b>	Multiple document templates.
<b>Program development:</b>	MS Visual C++ 6.0.

# 2 GENERAL

SCS\_PPOS is the parking Point Of Sale (PPOS) module of the Softcon SoftWin3 range of programs. It is used in two modes:

**Pay On Entry.** Payment is on entry, the amount paid is fixed for the vehicle type and does not depend on the period parked – exit is not controlled by the system. It controls an Entry lane. The operator optionally records the vehicle details via a keyboard (color, registration and number of passengers), optionally prints an entry pay slip. On selection of the SALE key, the entry barrier and the till are controlled and the entry is logged. Access cards are not used. Where security is required, slips with vehicle details are printed and handed to the driver and presented to security staff at the exit barrier who open the barrier if vehicle details match the printed details.

**Pay On Exit.** Payment is on exit. The amount paid depends on the vehicle type and on the period parked. Pay On Exit functions with access cards. Cards are presented at entry readers, setting the entry time. On exit, cards are presented at an exit reader linked to PPOS, controlling an exit barrier and the till on selection of the SALE key. The exit is logged.

Pay on exit can also control an entry barrier, recording the entry time for the card, the operator optionally recording the vehicle details (displayed on exit), optionally printing a slip and opens the entry barrier on the selection of the SALE key. When controlling an entry barrier, the PPOS terminal is typically installed between the entry and exit lanes.

Generally serial readers (entry, exit or entry/exit) are connected directly to the PPOS PC. Alternatively, any LAN based access reader linked to the Softcon SCS\_Client program can be set as entry reader or exit readers.

An optional card guest system can be incorporated, that is swiped when payment is required – requesting free payment from the guest system.

SCS\_PPOS can be installed and run on many PCs as required and requires a link to the program SCS\_Server that interfaces to the system databases.

SCS\_Server communicates with the databases and links via TCP communication links to client programs that can be running on the same and/or on different PCs. The program SCS\_PPOS described in this document.

Different [languages](#) are accommodated via configuration databases.

# 3 START-UP

The Softcon program SCS\_Server.exe must be running before the client program is started. SCS\_PPOS can be started with the following parameters:

<b>/start</b>	Starts and links to the previous server selected, with the password shut down with.
<b>/start:???</b>	Starts and links to server running on PC ???, with the password shut down with. ??? is the network name or IP address of the PC.

These parameters can be viewed in help about or by starting the program with the parameter */?*

The Softcon program SCS\_Server.exe can be started with the following parameters:

- /audit** All database editing is logged to the daily audit file c:\softwin3\audit\auyymmdd.mdb.
- /language:???** Selects language ????. Requires the appropriate language fields in the configuration databases. See [language](#) in SCS\_Edit.hlp set-up.
- /start** Starts with the password shut down with.

These parameters can be viewed in help about by right clicking on the dialog name bar (blue section on the top) or by starting the program with the parameter **/?**

When SCS\_PPOS starts running the following occurs:

- Initialises the server for communication.
- Opens event log-files.
- Starts RPC service.
- Connects to the server application.
- Receives the client RAM information.
- Creates the client RAM temporary tables.
- Loads and checks the client RAM.
- Starts the check connection task.
- Starts the analyze task.
- Starts COM port tasks.

## 4 CLOSING

- Stops COM port tasks.
- Stop the analyze task.
- Frees the client RAM.
- Stops the check connection task.
- Closes the client RAM temporary database.
- Stops system thread for connections to daily log-databases.
- Sends "bye" to the server application.
- Stops RPC service.

# 5 CONFIGURATION

The configuration of a PPOS terminal (lane) is as per the diagram below. When using a guest card system, or when Pay on Exit, the reader(s) is tied to COM port(s) via serial interface or is integrated in the keyboard.

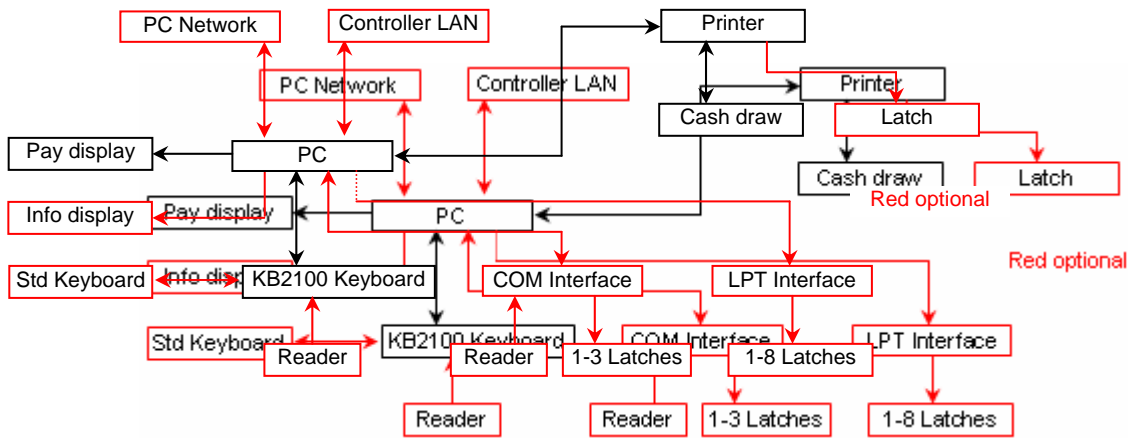

In **Pay On Entry** implementations, two access points can be controlled on selection of sale, e.g. the barrier for vehicles via the printer port, and a latch via the serial interface for a pedestrian turnstile. The item set-up (setting vehicle type, pedestrian) links item to output port. LAN controllers are not used.

In **Pay On Exit** implementations, **Entry**, **Pay** or **Entry/Pay** readers could be tied to PC COM ports or be integrated in the keyboard. Entry marks card with entry time, optionally allows the entering of vehicle details via the keyboard (displayed on exit) and activates the entry latch relay on selection of sale. The pay reader performs PPOS functions, activating an exit barrier relay on selection of sale.

**Access control readers** linked to the Softcon SCS\_Client program can be configured as **Entry** or **Pay** readers, passing the card details to PPOS, functioning as described above (as if the readers are connected directly to PPOS PC). The SCS\_Client program could be running on the same PC or on PCs linked to the PPOS PC via PC networks. When vehicle details need not be recorded, entry readers could be set to not be linked to PPOS, automatically setting the entry time and opening the entry barrier.

The **keyboard** generally used contains dedicated keys for the relevant functions with a standard keyboard only installed when set-up settings are edited.

The **slip printer** is serial, parallel or USB.

**Barrier and turnstiles** are controlled via the auxiliary output on the printer or via 'Latch' outputs that are available via the Softcon serial COM interface (3 outputs) or the Softcon parallel LPT interface (8 outputs).

The **info display** (typically a 4 line LED display) is optional and the **pay display** (a one line LED display, displaying the vehicle type and the amount due) is generally installed. The displays are connected to the serial COM ports.

# 6 SET-UP

## 6.1 Set-up Editor

### 6.1.1 PC I/O SET-UP

Serial (via COM ports) and parallel (via LPT ports) interfaces can be connected to PCs, connecting card reader/writers, barcode readers, inputs (monitored inputs to the systems) and outputs (controlled outputs) to the system. For serial COM devices, the bit per second (**Baud**), **DataBits**, **Parity**, **StopBits** and **Flow** is set via list selections. The **Application** (SoftWin3 program) and **PC** where the programs runs are selected from lists. The **Source** selects the type of function the I/O data is referenced and is selected from one of the following:

<b>Bar Code</b>	Serial data from item reader - POS, asset track.
<b>Barrier Entry</b>	Output to entry barrier PPOS.
<b>Barrier Exit</b>	Output to exit barrier - PPOS.
<b>Card</b>	Serial data from card reader - card edit.
<b>M2M Controller</b>	Serial data to/from controller.
<b>Park Entry</b>	Serial data from entry reader – PPOS.
<b>Park Entry/Exit</b>	Serial data from entry/exit reader – PPOS.
<b>Park Exit</b>	Serial data from exit reader – PPOS..
<b>Payment</b>	Serial data to pay display –POS, PPOS.
<b>Screen</b>	Serial data to screen display (4 line display, displaying messages, adverts, etc.) – POS, PPOS.

**Type** selects the PC interface (COM1 to COM8, LPT1 to LPT8). Softcon serial interfaces have 3 outputs and parallel interfaces have 8 outputs, the appropriate output of an interface is selected via the **Port** number (1 to 3 for serial and 1 to 8 for parallel) for the item (see item set-up).

**LPT\_Address** base settings vary on certain PCs. When using a LPT device, the address must be set to match the PC setting in: Settings\ Control Panel\ System\ Hardware\ Device Manager\ Ports LPT?\ Properties\ Resources.

### 6.1.2 PPOS CARDS

Cards used in the pay on exit system are edit via the list editor or by right clicking on a card in the list and selecting properties. The following can be viewed or edited (password protected):

The **General page** contains general personal information regarding the cardholder and has no effect on the functioning of the system. The data is editable and is not checked for format or contents, and is not changed by the system when the card moves. The data descriptions, the type and length of data, can be changed via set-up tables.

#### Personal Details for Card holder

<b>Title.</b>	Selected from a list. The list can be added to via a list editor in set-up list menu.
<b>Surname.</b>	Holders surname. This field is often used to enter the surname and first name.
<b>First Names.</b>	
<b>ID number.</b>	ID number (or passport if no ID number).
<b>Gender.</b>	Selected from a list. The list can be added to via a list editor in set-up list menu.
<b>Employ nr.</b>	Company employment number, or "VISITOR - company name".

#### Contact Numbers

<b>Home.</b>	Telephone numbers.
<b>Work.</b>	Telephone numbers.
<b>Cell.</b>	Telephone numbers.
<b>Other.</b>	Telephone numbers.

#### Address

<b>Address 1.</b>	Street or Apartment number and name.
<b>Address 2.</b>	
<b>Suburb.</b>	If applicable.
<b>City.</b>	

	<b>Postal code</b>	
	<b>Email.</b>	
<b>Business</b>		
	<b>Company.</b>	Generally used for contractors or visitors.
	<b>Department.</b>	Selected from a list that is editable via a set-up list editor.
	<b>Description.</b>	Work description.
<b>Vehicle info</b>		
	<b>Car registr 1,2,3.</b>	Registrations of all vehicles that can be used to site, e.g. NVR664T.
	<b>Description 1,2,3</b>	Description of the vehicles, e.g. Grey BMW.
<b>Other info</b>		
	<b>Citizenship.</b>	Country of citizenship (optional).
	<b>Union affiliation.</b>	Selects the trade union the cardholder is affiliated to (optional).

The **Status page** contains Access control information of the card. Data as the cards location is not editable and most of the data is editable via list selections. The data descriptions can be changed via set-up tables, but type should not be changed. The details of how access is granted or denied are described in the document SCS\_Card\_Access.

### Locations and Groups

<b>Location and Time.</b>	The current location of the card and when it moved there (year-month-date, hr:min:sec).
<b>Previous location.</b>	The previous location of the card, i.e. the previous area zone it was in before the last time the card was used.
<b>Area Group.</b>	Area groups define to which area zones the cardholder may be granted access to. Many cards may be allocated to the same group (e.g. "Area group - managers" with access to all zones) or the card can have its own unique group. The area group is edited by selecting  which access SoftZone.
<b>Multi Group.</b>	Cards can belong to multiple groups, e.g. to the parking group, the admin group and the management, each giving access to certain area zones. If any of the allocated groups has access, access is permitted.
<b>Expire Area Group add.</b>	Defines additional area zones the cardholder may be granted access to when the card expires.
<b>Expire Area Grp delete.</b>	Defines area zones the cardholder may not be granted access to when the card expires.
<b>Count Area Group add.</b>	Defines additional area zones the cardholder may be granted access to when the cards counters are full (see zone counting).
<b>Count Area Grp delete.</b>	Defines area zones the cardholder may not be granted access to when the card expires.
<b>Time Group.</b>	Defines when a card may be granted access. One of 15 access time groups are selectable (with 8 time zones), e.g. "Time group 1 - managers" with 24 hr access. The first 15 time groups have been configured for the Softcon access controller CR351/4 and only these must be used if the data is to reside in the CR351/4 controller.
<b>Trigger Group(V).</b>	A trigger group can be allocated that is used in triggered events (e.g. when entering an area, the group counter is incremented). This group is set in the Value element of a card event.
<b>CD Count AreaGroup.</b>	A group can be allocated, and when the cardholder enters an area selected in the group (e.g. the canteen), the card counters are decremented.
<b>Capture Group.</b>	The card can be set to capture when entering specific areas. Set-up groups are set with the zones to which cards are captured and a capture group is set for the cards to be captured. Typically a group is set to capture at building exits, another at parking exit only.
<b>Park Start.</b>	When the card enters through a reader set as a <b>park entry</b> or <b>park pay</b> reader, the PC date/time is automatically entered in the park start field. The data is automatically cleared when exiting at a <b>park exit</b> reader.

**Accumulation Data** - The time accumulation total for the card is not editable and is calculated by the system, and represents the totals since the last day-, week- and month-end.

<b>Day.</b>	Card total for the present day.
<b>Week.</b>	Card total for the present week.

<b>Month.</b>	Card total for the present month.
<b>Hr/week.</b>	Data used in reports – typically the minimum hours required per week.
<b>Hr/leave.</b>	Data used in reports – typically the hours leave used during the current week.

**Status** – Each card is set with a status of Disabled, Enabled or Capture. When the card has expired, the **expired status** is used and when the cards count is full, the **count full status** is used. Typically an expired card becomes capture.

**Counts** - Parameters in this section are used only in certain installations when counting of the card in to a specific area zone is required (e.g. in to a canteen) or in vending type applications All the parameters are editable, with the value and entries parameters being update by the system as the card moves in to certain area zones. Two counters are available for a card, a normal (overall) counter and a period counter (which limits entries within the **Period** set). For example limit to 3 entries per day (period counter limit of 3, period of 0000-00-01) with a total limit of 25. Both counters increment (or both decrement) whenever there is an entry to the counting area zone. These are the **count now** and the **Pcount now** values. When either counters reach the limit as set in **count limit** and **Pcount limit** (or zero if decrement), the Count full area group add zones are added and the delete group zones are denied access. The cards status is changed to the **Count full status**. For example a card could become be a capture card or be disabled, or not given access to the counting area zone. The period counter is automatically reset to the **Plimit** (if counting up) or to 0 (if counting down) when the card enters in a new period (e.g. in a new day) and the **period next** changes to the end of the period.

**Zone counts** can be set to increment or decrement in the general set-up menu.

<b>Count Now, limit.</b>	The current overall count is displayed and is updated by the system when the card entered the count zone. The limit is the maximum number of times the card can enter the count zone.
<b>Period.</b>	Time period of the period counter, limiting the card to the count zone according to the period count limit.
<b>Pcnt Now, limit.</b>	The now value of the period counter and the limit value of the period counter.
<b>Last date.</b>	The last date the period counter started.

The **Card Info** contains card related Access information.

**CARD Info** - Data in this section is editable and is not altered by the system.

- Number 1, 2.** This number is the true number encoded in to, or on to the card or tag. In most installations, the number is equal to the card reference number. This number is only used for readers set with DB10, for other settings, the reference number is used as the card number. Readers are set to use cards 1 or 2 (e.g. MAG and PROX card). For DB10, the number of digits for number depends on the setting in the general set-up menu. For example when set to 5, 5 digits must be entered for number, with leading zeros to make up the 5 digits. The default set in the XLI files is 1, thus requiring no leading zeros.
- Issue 1, 2.** Certain card types use issue numbers that typically follow the card number. The issue number can be read as part of the card and wrong issue cards are rejected. This requires a setting in set-up/general set-up/cards. The issue number can be set (also in cards mask menu) to auto increment when the card is programmed.
- Previous.** This number indicates the previous card number the cardholder used and is only used for documentation purposes and does not affect the functioning of the system.
- Host** A card number can be linked to a host card, only being allowed access via a reader which gives access to the area (or linked area) in which the host is in. The linked number is the reference number of the host, not the card number. This option is also referred to as **Follow me**.
- Visitor ref.** If the card is a visitor card, as entered by the visitor system, the last visitor reference (i.e. the visitor that last was allocated to use the card) is displayed. If a normal card, the reference is zero.
- Pin code.** A pin number can be allocated to cards when pin pads are installed. Depending on the set-up of the Pin Pad and reader time groups, access is via either card or pin code or both. Cards set with a pin code of zero, gains access only by card, no pin is required. Should more than one cardholder have the same pin code and access is only by pin (no card is swiped), the system reports access to the holder of the pin code first found in the database (starting at card 1). When cards and pin codes are used, the correct card is reported. A 9 in the last digit of the code is reserved for duress report, i.e. when a

- cardholder changed the last digit to 9, a duress alarm is generated (access is granted if the card normally has access).
- Issued.** This is the date and time the card was issued and serves as the enable time for the card. The card will not function before this date/time. The format is year-month-date hour:minute (e.g. 1986-12-30 11:50).
  -  Sets the issues to date/time of the PC and the expires time as defined in the expire mask in the General set-up menu
  - Expires.** The card expires on this date/time. The format is the same as above.
  - Expire Status.** The status of the card when expired, e.g. when the card is expired, it is a capture card, normally it is enabled.
  - APB Reset.** When checked, the card has a free APB movement, i.e. when attempting to gain access via an APB reader and the card has access but has an APB error, access will be granted.
  - Passback.** A card set as a passback card, overrides anti-passback, i.e. the card can be used for multi-access to the same area zone without the requirements to exit the zone (as is required for anti-passback). The required option is selected by clicking in the down arrow and clicking on the required option.
  - Ext Access.** Sets the card to be controlled by the external linked system for access requests at readers marked as Ext Access. These cards are not stored in the controller and access is granted or denied by the external system.

### 6.1.3 PPOS COLOURS

The **reference** number of colours allocated to vehicles are logged. The **type** descriptions are displayed and printed.

### 6.1.4 PPOS CONTROLLERS

**Descriptions** are set for controllers and **types** are set (currently only POS translators must be selected), enabling the selection of correct translators by venders.

### 6.1.5 PPOS FARE

**Fare** is used in pay on exit only (amounts charged for pay on entry are set for the item in the item set-up menu). Fares are set in units (e.g. cents) are linked to **groups** (e.g. vehicle group, bus group, pedestrian group) – items are linked to the appropriate group. The **Period** is set for the fare (e.g. 10 minutes) – the fare for the selected item is referenced by the items group, with the maximum period that is the is less than period present. For example group vehicle has set fares of abc for period 10 (abc for 0 to 10 minutes), bcd for period 30 (bcd for 11 to 30 minutes) and fare efg for period 60 (above 60 minutes).

A **Time group** selection is set when a fare is fixed (does not depend on the period present), e.g. at night and on Sundays, e.g. fare xyz for group vehicle is set with time group After-hours, with after-hours set for 18:00 to 06:00 for week-days and for 06:00 to 18:00 for Sundays. On exit, if entry and exit times for the selected group are in a active time-groups, the fare is used (e.g. entered after 18:00 and exit before 06:00). If either entry or exit are not in an active time-group, the period fare used (e.g. entry at 17:00, exit at 20:00, fare for 180 minutes is charged).

### 6.1.6 PPOS ITEM GROUPS

Items (e.g. car, taxi) are allocated to groups. Fares are set for the groups.

### 6.1.7 PPOS ITEMS

For pay on entry, the price of parking is set per item (which is linked to a **Vender**, linked to a PC) via the **Charge** value (in units, e.g. cents) set in the items set-up. Description is a name given to the item (e.g. "Car, Bus, Taxi, Pedestrian"). The item key is a number linked to the keyboard item value (e.g. 1, 2, 3, 4).

Each item is added for the vender (by right clicking on the display area under the column headings and selecting **Add record** and a **Description** is entered. To remove an item, right click on the item line and select **Delete record**.

·**Group** sets the classification of the item for reporting purposes and for linking the item for a fare group in pay on exit applications. Groups are edited in the Group set-up menu.

·**Barcode**, **Report**, **Report TG**, **Last DT**, **Subsidy**, **key**, **price**, **Total**, **now**, **reset**, **Unit** and **Use price** are not used in PPOS (only for vending or POS items).

**Details** set whether vehicle details are required, optional or not and if required, the sections of colour, registration, etc. must be set before the sale can be completed.

**Entry Relay** selects the contact controlled when the sale is completed (Pay On Entry) or on entry (Pay On Exit) and is a relay controlled via the printer port or the relay connected to a Softcon interface connected to a COM serial port. **Entry Pulse** sets the time in seconds that the contact on the Softcon interface is closed (fixed for the printer relay). This relay selection allows two entrances to be controlled via one PPOS (e.g. a vehicle barrier and a pedestrian turnstile).

**Exit Relay** selects the contact controlled when the sale is completed (Pay On Exit) and is a relay controlled via the printer port or the relay connected to a Softcon interface connected to a COM serial port. **Exit Pulse** sets the time in seconds that the contact on the Softcon interface is closed (fixed for the printer relay). This relay selection allows two entrances to be controlled via one PPOS (e.g. a vehicle barrier and a pedestrian turnstile).

**I/O Port** selects which output port of the Softcon serial or parallel interfaces are controlled for the item on park entry or exit.

### 6.1.8 PPOS KEYBOARD

A variety of keyboards can be used for PPOS. The PosiFlex KB2100 must be programmed as follows (Generally only Pay on entry only marked with \*, pay on exit only, marked with #):

<b>A1</b> lock	<b>B1</b> unlock													<b>L2</b> sale
<b>A2*</b> GP	<b>B2*</b> WP	<b>C2*</b> Black	<b>D2*</b> Red	<b>E2*</b> number		<b>G2*</b> passen		<b>H2</b> car	<b>I2</b> amount	<b>J2</b> logon	<b>K2</b> print			<b>L3</b> cancel
<b>A3*</b> N	<b>B3*</b> EC	<b>C3*</b> Blue	<b>D3*</b> Silver	7	8	9	<b>H3</b> taxi	<b>I3</b>	<b>J3</b> logoff	<b>K3</b> accept				
<b>A4*</b> MP	<b>B4*</b> NC	<b>C4*</b> Gold	<b>D4*</b> White	4	5	6	<b>H4</b> bus	<b>I4</b>	<b>J4</b> passw	<b>K4</b> clear				
<b>A5*</b> NW	<b>B5*</b> FS	<b>C5*</b> Green	<b>D5*</b> Yellow	1	2	3	<b>H5</b> pedestr	<b>I5</b> previou	<b>J5</b> takeon	<b>K5</b>				
<b>A6*</b> ZN	<b>B6*</b> Other	<b>C6*</b> Grey	<b>D6*</b> Other	0		.	<b>H6</b> lost	<b>I6</b> next	<b>J6</b> cashup	<b>K6#</b> reader				

The keyboard is programmed to transmit A1, A2, A3 ... L3 and can currently only be done by running the RWM with the parameter `0.TPL` in the directory `...` via the **PPOS keyboard** set-up (le), with **values** set as required. The functions of the key types are described under **PPOS** below.

When the keyboard is in the locked mode (by turning the key to the locked position), the take-on and cash-up keys do not function. The PC set-up setting of unlock, enables the take-on and cash-up keys, regardless of the keyboard key position.

Key inserts at 1:1 as follows:

<b>GP</b>	<b>N</b>	<b>MP</b>	<b>NW</b>	<b>ZN</b>	
<b>WP</b>	<b>EC</b>	<b>NC</b>	<b>FS</b>	<b>Other</b>	
<b>Black</b>	<b>Blue</b>	<b>Gold</b>	<b>Green</b>	<b>Grey</b>	
<b>Red</b>	<b>Silver</b>	<b>White</b>	<b>Yellow</b>	<b>Other</b>	
<b>Amount</b>	<b>Car Number</b>	<b>LogOn</b>	<b>LogOff</b>	<b>PassW</b>	
<b>TakeOn</b>	<b>CashUp</b>	<b>Car</b>	<b>Bus</b>	<b>Taxi</b>	<b>Lost</b>
<b>Persons</b>	<b>Clear</b>	<b>Previous</b>	<b>Print</b>	<b>Next</b>	
<b>Sale</b>	<b>Cancel</b>	<b>Accept</b>	<b>Reader</b>	<b>Pedest</b>	

Ref	Key	Type	Value	System
1	A1	18 Lock	Lock (Normal)	Entry/Exit
2	A2	1 Province	GP	Entry/Exit
3	A3	1 Province	N	Entry/Exit
4	A4	1 Province	MP	Entry/Exit
5	A5	1 Province	NW	Entry/Exit
6	A6	1 Province	ZN	Entry/Exit
7	B1	19 Unlock	Unlock (Supervisor)	Entry/Exit
8	B2	1 Province	WP	Entry/Exit
9	B3	1 Province	EC	Entry/Exit
10	B4	1 Province	NC	Entry/Exit
11	B5	1 Province	FS	Entry/Exit
12	B6	1 Province	OTHER	Entry/Exit
13	C2	3 Car colour	Black	Entry/Exit
14	C3	3 Car colour	Blue	Entry/Exit
15	C4	3 Car colour	Gold	Entry/Exit
16	C5	3 Car colour	Green	Entry/Exit
17	C6	3 Car colour	Grey	Entry/Exit
18	D2	3 Car colour	Red	Entry/Exit
19	D3	3 Car colour	Silver	Entry/Exit
20	D4	3 Car colour	White	Entry/Exit
21	D5	3 Car colour	Yellow	Entry/Exit
22	D6	3 Car colour	Other	Entry/Exit
23	E2	5 Amount	Amount	Entry/Exit
24	G2	2 Car Number	Car Number	Entry/Exit
25	H2	11 LogON	LogON	Entry/Exit
26	H3	12 LogOFF	LogOFF	Entry/Exit
27	H4	15 Password	Change Password	Entry/Exit
28	H5	16 TakeOn	TakeOn	Entry/Exit
29	H6	17 CashUp	CashUp	Entry/Exit
30	I2	7 Item	Car	Entry/Exit
31	I3	7 Item	Taxi	Entry/Exit
32	I4	7 Item	Bus	Entry/Exit
33	I5	7 Item		
34	I6	7 Item	Pedestrians	Entry
35	J2	9 Clear	Clear	Entry/Exit
36	J3			
37	J4			
38	J5	14 Prev	Previous	Entry/Exit
39	J6			
40	K2	6 Print	Print	Entry/Exit
41	K3	20 Accept	Accept	
42	K4			
43	K5	13 Next	Next	Entry/Exit
42	K6	21 Reader	Reader	Exit
45	L2	8 Sale	Sale	Entry/Exit
46	L3	10 Cancel	Cancel	Entry/Exit

### 6.1.9 PC

The PCs in the system are set as follows:

PC **reference** number.

PC network **name**.

**PPOS type** sets the PPOS to function as Pay on Entry or Pay on Exit terminal.

Serial **Entry reader type** connected to the PC. For Pay on Exit systems, cards swiped at the entry reader are marked with entry time (LAN readers could also be set as entry readers). For Pay on Entry systems, the card number is passed (with the amount due) to an external system to request free parking. If the reader is integrated in the keyboard, 'wedge' is selected, if no entry reader, select 'none'. Serial reader properties are set in COM properties – Entry.

Serial **Exit reader type** connected to the PC. Only used for PC set as a Pay On Exit terminal. If the reader is integrated in the keyboard, 'wedge' is selected, if no exit reader, select 'none'. Serial reader properties are set in COM properties – Exit. See PPOS [reader mode](#) description below for functionality.

Serial **Entry/Exit reader type** connected to the PC. Only used for PC set as a Pay of Exit terminal. If integrated in the keyboard, 'wedge' is selected, if no entry/exit reader, select 'none'. Serial reader properties are set in COM properties – Entry/Exit. See PPOS [reader mode](#) description below for functionality.

**POS vender** sets the vender linked to the PC.

**Details mode** (was speed mode) is set to Required, Optional, None. None results in vehicle and passenger details not being required or displayed in PPOS. In most Pay On Exit implementations, details mode is generally none. Required and optional displays the details on the PPOS screen, required forces the entry of the data before a sale can be made.

When an INFO LED **display panel** is installed, the display lines are set in **Line1 2 3 and 4**. Certain display panels have multiple pages. The **Screen page** setting select the page on which the data is displayed.

The last **Take On** amount entered at the PPOS.

**Cash Up** displays the total amount of money taken since last take-on.

**Car Free** displays the number of vehicles that had free entries since the last cash-up.

**Car Paid** displays the number of vehicles that paid since the last cash-up.

When checked, **Ppos Lock** locks the PC in the normal mode (not in supervisor mode, cash up and take-on buttons are disabled). This is the equivalent of the keyboard in the lock position.

**Master DT** sets the PC from which time/date is synchronized. See [Date/time properties](#).

**PPosDPay** sets the payment display used.

## 6.1.10 PPOS PRINTERS

Printers connected to the PPOS **PCs** are configured to the number of **slip copies** automatically printed. The **Windows name** for the printer must be set. Slip printers such as the Posiflex printer are generally installed as a Generic/Text Only printer, refer to the printer manuals for the Windows driver installation. The formats of the slips are configured via .txt files in the directory c:\SoftWin3\templet. The file PPOSdescriptions.txt lists the commands that can be used in the files and lists the files used when printing. The commands are:

- @@21 - Company name
- @@22 - Entry Date/Time
- @@23 - PPOS Number (Vender Number)
- @@24 - Visitor Name (from swap card)
- @@25 - Car Number space Car Province
- @@26 - Car Colour
- @@27 - Number of passengers
- @@28 - Fare (Vender Item Charge)
- @@29 - Amount
- @@30 - Change
- @@31 - Current User Name
- @@32 - Count of free cars
- @@33 - Count of paid cars
- @@34 - Take ON Amount
- @@35 - Cash UP Amount
- @@36 - Vender Item Name
- @@37 - Card Points
- @@38 - Card Type
- @@39 - Card Type Name
- @@40 - Exit Minutes
- @@41 - Exit Date/Time
- @@42 - Operator reference

The files are:

- PPos.txt - Visitor must pay, open draw, open barrier
- PPosPrn.txt - Print Last Sale
- PPosFree.txt - Free, open barrier
- PPosFreePrn.txt - Print Last Free
- PPosDeduct.txt - PR (deducted), open barrier
- PPosDeductPrn.txt - Print Last PR (deducted)

PPosCashUp.txt - Print Cash UP, open draw  
 PPosCashUpPrn.txt - Print Cash UP  
 PPosTakeON.txt - Open draw  
 PPosPrnRelay.txt - Visitor must pay, open draw, open barrier from serial port  
 PPosEntry.txt - Entry sleep, open barrier  
 PPosEntryPrn.txt - Last Entry sleep

### 6.1.11 PPOS TYPE

Sets the PPOS type descriptions. Additional types to be added by Softcon on request. This menu is generally hidden and the data will never be edited (unless the wording requires changing).

### 6.1.12 PPOS PROVIDICE

The **reference** number of provinces allocated to vehicles are logged. The **type** descriptions are displayed and printed.

### 6.1.13 PPOS VENDER

A **name** is set for each PPOS terminal, linking it to a controller (referencing to a translator). Currently the **PORT** number is always set to 1. Items (e.g. car, taxi) are linked to a vender.

## 6.2 TIME GROUP ZONE

Time groups are used to set different fares on different times of day, e.g. day, after hours, night. See [Fares](#). Generally any of the system time group sets are used (other groups are used for access control, buzzer, etc.).

## 6.3 GENERAL SET-UP

### 6.3.1 External System

If used, the links to external programs are set in the External Set-up menu. The settings are:

The data obtained from the external system is selected by checking on the options:

- Vending.** Control of the entry is controlled by the external system.
- Cards.** Card database info is obtained from the external system.
- External Vend Item.** The cost of the items provided by the external system (price of the parking).
- Use card number.** Card number and not card reference is used to identify the card.

**Card Mask** sets what the characters received from the readers that are passed to the linked systems. Cardholders can have two cards (card 1 and card 2), and the readers in the system are set to use card set 1 or 2. The mask is set for each card set. **Keyboard card mask** is for a reader integrated with the PC keyboard. Integrated MAG readers have a leading ; and end with ?. These characters are used to identify a reader string.

The communication type is set in the **Talk** selection to **Serial** or **TCP/IP** and the data structure is selected by **Type** to be **Softcon**, **SI** or **Tsogo**. More structures could be added upon request.

**TCP/IP Host** sets the network name of the PC where the external system program runs and the **TCP/IP port** and **Listener port** sets the port address of the external program and the port address of the Softcon client program used by the external program.

**Site ID** sets the name to be printed on the slip.

**COM Reader Card Mask** is the mask on the data received from the serial reader connected to the COM port. This data is used to find the data in the externally linked database.

When messages are sent to an external system, a reply must be received within the **Delay** time (in msec.), if not the message is repeated **Repeat Count** time before being discarded.

**Routing** and **Terminal** setting are used in certain messages and protocols.

When communication is successful, a green dot icon is displayed. A Red dot indicates comms error.

## 6.4 **Print. Ctrl+P**

When in certain menus, the print option is active. In list editors, the selected lines are printed with column headers and column widths.

## 6.5 **Print preview.**

When the print option is active, the preview is active – showing a print preview for the default printer.

## 6.6 **Print setup.**

Enters the Windows printer set-up menu.

## 6.7 **Log fields**

The optional fields that are logged are enabled by ticking the appropriate fields in the log fields set menu. Field description lists the general events that have data in these fields. See logging in SCS\_Client for more details.

## 6.8 **Date and time properties**

Changing the time and date of the local PC via this menu results in the change being sent to all PCs running linked Softcon SoftWin3 programs (connected to the same SCS\_Server.exe application). The changed date/time is also sent to all controllers. PCs date/times are synchronised with the PC set as the **Master DT (PC set-up)** when the applications start and every 90 minutes thereafter. When PCs connect via the distribution server, date/time is set to that of the PC set as Master DT.

Note that changing the date/time via Windows applications will not result in the immediate sending of the changes to controllers or other PCs – this will only be done when the controllers are sent a set-up, become on-line, when applications start or when the automatic periodic synchronizations occur (once an hour for controllers, 90 minutes for PCs). The Windows time/date set applications should thus not be used and should be disabled via policy editors.

# 7 **SCS\_CLIENT LINKS**

When SCS\_CLIENT controllers are linked to PPOS, the following settings are required:

**ENTRY, NO DETAILS.** As no vehicle details are required, no PPOS actions are required. The reader is set as type **ENTRY** and card presented at the reader are automatically as marked with the entry date/time (is no date/time is already set. The cards must be enabled for the entry reader(s). SCS\_Client logs entries as normal.

**ENTRY, DETAILS REQUIRED.** As vehicle details are required, the card number must be sent to PPOS for the operator to enter the details. As normal tenant cards could use the same readers that do not require PPOS functions, the PPOS cards are not enabled for the reader – the out-of-area event generated as a result are used as triggers to generate an **entry event** that is set to the appropriate PPOS PC. Should only PPOS card be sent to the PPOS terminal (not tenant cards that are out of area), PPOS cards must be set with a trigger group (e.g. PPOS group, group 1) that is used in the out-of-area trigger (in the **v** field). To transfer the card generating the trigger to the entry event, the trigger reverence is set (e.g. -10 in the example below results in the card Xref being transferred to the Park Entry event).

**EVENT** [X]

Event Name: 2 PPOS entry reader

Algorithm: 10

PC	Program	Type	System Item	Status	Value	Xref	Alarm
localhost	SCS_PPoS	Reader	Rd1 In	Park Entry	1	-10	0

EVENT TRIGGERS

Ref	Type	System Item	Status	Value	Xref	Alarm
10	Reader	Rd1 In	Out-of-area	1	0	0

EXIT. Readers are set as normal readers. PPOS cards are not allowed access, resulting in out-of-area messages. An Park **Exit event** is set to be sent triggering on out-of-area and on a trigger group set for the PPOS cards..

**EVENT** [X]

Event Name: 3 PPOS exit reader

Algorithm: 11

PC	Program	Type	System Item	Status	Value	Xref	Alarm
localhost	SCS_PPoS	Reader	Rd 02 out	Park Exit	1	-11	0

EVENT TRIGGERS

Ref	Type	System Item	Status	Value	Xref	Alarm
11	Reader	Rd 02 out	Out-of-area	1	0	0

## 8 PPOS

The PPOS display on the PC screen displays the following:

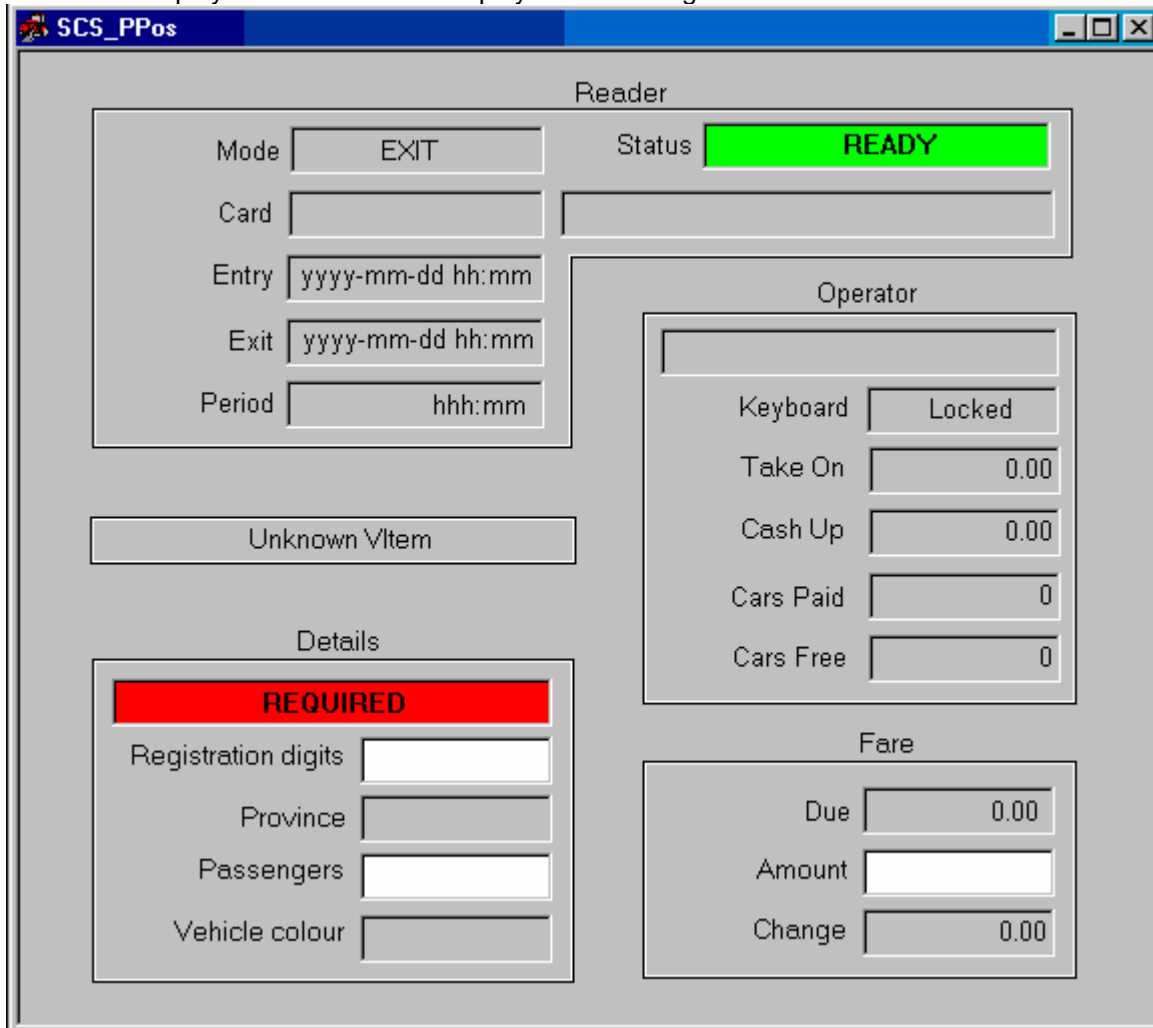

The screenshot shows a software window titled "SCS\_PPos" with a "Reader" section at the top. The "Mode" is set to "EXIT" and the "Status" is "READY" (highlighted in green). Below these are fields for "Card", "Entry" (yyyy-mm-dd hh:mm), "Exit" (yyyy-mm-dd hh:mm), and "Period" (hhh:mm). A button labeled "Unknown VItem" is present. The "Operator" section includes a "Keyboard" status (Locked) and fields for "Take On" (0.00), "Cash Up" (0.00), "Cars Paid" (0), and "Cars Free" (0). The "Fare" section has fields for "Due" (0.00), "Amount", and "Change" (0.00). A "Details" section features a red "REQUIRED" banner and fields for "Registration digits", "Province", "Passengers", and "Vehicle colour".

### READER

**Reader mode.** Only displayed for Pay On Exit and only when a reader is a multi-function reader. The current mode of the reader is displayed. Selection of the **Reader** key toggles the mode between EXIT and ENTRY if a PC reader type of entry/exit is set, and toggles with GUEST (if linked to external guest system), i.e. Entry/exit (entry/ exit reader set), exit/guest (exit reader set and guest system), entry/exit/guest (entry/exit reader and guest system). If only one of the modes is available, the mode is not displayed and the reader key has not effect.

**Exit reader:** The reader defaults to EXIT. When a card is swiped, the exit time is recorded and amount due displayed. If linked to an external guest system, the reader mode automatically becomes a GUEST reader - the card number that is then swiped is passed to an external system (with the amount due) to request free parking. After sale, the reader automatically defaults back to an EXIT reader.

**Entry reader:** The mode displays ENTRY and functions as an ENTRY type reader on selection of the **Reader** key on the keyboard – **for one swipe only** (defaulting back to EXIT reader). The entry time is logged to the card.

**Guest card, name.** Only displayed when a external guest system in used, displaying the card guest card swiped at the serial reader or the reader that is integrated in the keyboard. The holders name received from the external guest system is displayed.

**D/T entered.** Date/time entered.

**D/T exit.** Date/time exited, only displayed for Pay On Exit.

**Period present.** Time period present (=exit-entry), only displayed for Pay On Exit. Displayed as hhh:mm.

### ITEM

The type of vehicle items (e.g. car, taxi, bus) is made on the keyboard. The item selected is displayed. Fare – due

displays the charge for the selected item. For pay on entry, the prices are set in the vender item set-up menu and for pay on exit, the prices are set in the Fare set-up menu and depends on the time present

## DETAILS

The mode displays **NONE** (PC details set to none or optional - and item is none), **OPTIONAL** (PC and item set to optional) or **REQUIRED** (PC set to required or optional – and item is required). When required, all the vehicle details and the number of passengers must be entered before the sale can be done. When optional, the entering of the data is optional. When set to none, the details are not displayed. On exit, the details entered on entry are displayed.

**Registration digits.** The registration digits of the vehicle. It is suggested that the digit 0 is entered for each of the characters on the registration, e.g. MTL120 is entered as 000120.

**Province.** The province of the vehicle registration.

**Passengers.** The number of passengers in the vehicle (including the driver).

**Vehicle color.** The vehicle colour.

## OPERATOR

The following information displays the statistics of the PPOS since the last take-on or cash-up:

**Operator.** The name of the logged on operator is displayed.

**Keyboard.** The keyboard mode of **locked** or **unlocked** is changed by turning the keyboard key. The mode can set to **unlocked** (keyboard key position ignored) by the PC set-up selection. In the locked mode, the take-on and cash-up keys are disabled.

**Take-on.** The amount entered on selection of the take-on key. The take-on key is only enabled with the keyboard lock is in the unlock position or the PC is set to the unlock position via the PC menu. On take-on selection all totals are cleared and the take-on (float) is entered. The take-on amount, the operator reference and the date/time are recorded as an event.

**Car Free entries.** Automatically incremented for the number of vehicles that entered free (via the card guest system in pay on entry, or time period was no charge in pay on exit).

**Car Paid entries.** Automatically incremented for the number of vehicles that paid on entry (pay on entry) or on exit (pay on exit).

**Cash up.** The total of the amounts paid plus the take on amount. As for the take-on key, the cash-up key is only enabled when the PC is set to unlock. On cash-up selection, a slip is printed and an event is generated, recording the take-on amount, the operator reference, the number of vehicles that paid and the amount taken and the number of vehicles that had free parking. All totals are cleared.

Additional operator functions available on the keyboard are:

**LogON.** Logs on a new user. The user name and password must be digits and is initially set by the system administrator.

**LogOFF.** Logs the user off.

**Password.** The user can change own password by entering the old password, followed by the new password and a confirmation.

## FARE

**Due.** The fare is free (if a guest card system is used and the guest has free entrance) or is as set for the item selected. For pay on exit, the fare depends on the period present.

**Amount.** The amount tendered for the payment can be entered as an option, and the change is automatically calculated and edited.

**Change.** The change to be given is the amount tendered less the fare.

Additional fare functions available on the keyboard are:

**Sale.** On entry, an entry slip(s) is printed (the number of prints are set in the printer set-up), the till opens (pay on entry and entry not free) and the entry barrier opens. When details are required, all the vehicle details and the number of passengers must be entered before the sale key is functional. On exit, an exit slip(s) is printed (the number of prints are set in the printer set-up), the till opens (exit not free) and the exit barrier opens.

**Print.** Reprints the entry or exit slip.

## 9 TOOLS

### 9.1 PASSWORDS

Menus and items on menus are set accessible to any number of password **groups**. Any number of **users** are set to be members of users groups, i.e. a users can belong to more that one group – e.g. Peter can belong to the Control Group and to the Vending Group and has access to any menu and item these groups are set for. Adding or deleting users and groups is described below. Password groups and users are created, deleted and edited by SCS\_CLIENT.

When logging on, a user must enter an identification name (not case sensitive) and a password (case sensitive). Passwords can be changed via the  [change password](#) selection by the user and can be set to automatically expire in the [general set-up](#) menu in SCS\_CLIENT.

Administrators in the menu access menu set access to menus.

### 9.2 Logon/off

Changes the logged on user.

### 9.3 Change Password

Changes the password of a user. The old password must be entered and the new password must be confirmed. Passwords are displayed with \*. Passwords can be set to expire automatically, see password period.

### 9.4 Menu Access

Sets the password groups that have access to the menus.

## 10 View



### 10.1 Toolbar

Displays the hot key toolbar. This bar of icons can be moved as required by clicking and dragging on the start of the bar.

### 10.2 Status bar

Displays the status bar at the bottom of the window. Selection messages are displayed and a green icon dot indicates that the SCS\_PPOS program is connected to the server program SCS\_SERVER. A red icon dot indicated not connected to the server.

## 11 WINDOW

Normal Windows ordering of multiple open windows is by the selection of  **Cascade**,  **Tile Horizontally** and  **Tile Vertically**

# 12 FUNCTIONING

Once the set-up has been done, operation of PPOS is via the PPOS menu. Generally this is the only menu available to the operator and cannot be closed by the operator. Assuming that the set-up of the keyboard is as the described default, functioning is as follows:

## Logging on/off

The operator enters the operator reference number and password on the digits keys. Note that the password can only be digits. The logged on operator name is displayed and on logged-off, logged-off is displayed and only the log-on key is active. All activities of PPOS are logged to the logged on operator.

## Take-on, cash-up

The number of free and paid entries, the take-on and cash-up amounts and the date/time, PC and operator names are printed on a slip and logged to disk. All totals are cleared and the operator is automatically logged off.

## Pay on entry

1. If the vehicle is different to the default type (Car), the operator selects the appropriate type (Car, taxi, bus, pedestrian). The type and the fare due are displayed on the pole display. If the PC setting for details is set to optional, the details mode displays **NONE**, **OPTIONAL** or **REQUIRED** according to the vehicle type selected. If not optional, the PC setting is displayed (none or required). If details are optional or required, the cursor defaults to the registration digits position, if none, the cursor defaults to the amount position.
2. If required, all the details have to be entered and if optional none, any or all can be entered. If none, no details can be entered (not displayed). In order to minimize the number of key strokes, the data is entered in the display order: **Registration digits** (entered on the **digits keys**, e.g. 1327), **Province** (selection of any of the **province keys**) – cursor jumps to - **Number of Passengers** (entered on the **digits keys**, e.g. 12), Vehicle **Color** (selection of any of the **color keys**) – cursor jumps to - **Amount** (the amount of money received, entered on the **digits keys**, e.g. 20). The province and color keys can be selected at any time, with the cursor moving to number of passengers or amount respectively. The cursor can also be moved to registration digits, number of passengers or amount by selection of the **Previous** or **Next** keys, or by selection of the **Number**, **Persons** or **Amount** keys. Entering the amount is optional and is entered to aid the operator in showing the change to be given. Errors in province and color are simply corrected by selecting the correct keys. Errors in registration digits, number of passengers or amount requires the cursor to be moved to the appropriate line, selection of the **Clear** key and entering the correct digits.
3. Selection of the **Cancel** key clears all the data and moves the cursor to the Registration digits.
4. If linked to and external guest system, the guest card is presented to the keyboard / serial reader. If free, the fare indicates free.
5. The **Sale** key only functions if the details are not required, optional or if required and all details have been entered. The sale key results in activation of the entry latch, opening of the till if the entry is not free and printing of a slip(s) if auto print is set in the PC printer set-up. The entry is logged (date/time, operator, PC, vehicle details, fare).
6. Selection of the **Print** key prints a slip.

## Pay on exit - entry

When using SCS\_Client access control entry readers not linked to PPOS, no entry functions are done by PPOS. The entry barriers open when cards are presented to entry readers, recording the entry date/time. If an entry date/time is already set for the card, the time is not overwritten.

When the entry reader is linked to PPOS, presenting a card to an entry reader activates the PPOS menu, displaying the card name and date/time of entry. A reader set as entry/exit defaults as an exit reader and PPOS displays the current mode as **ENTRY** or **EXIT**. Selection of the **Reader** key changes the reader between exit and entry. Rate, amount and change are not displayed and cannot be entered. Details are entered (if optional or required) as described for pay on entry above.

## Pay on exit - exit

1. The card is presented to the exit reader, displaying the card name, entry and exit times, the time parked and the rate (amount due). The details entered by PPOS on entry are displayed.
2. Vehicle type keys can be selected and details could be entered as described for pay on entry. Generally if details are required, they are set on entry, not on exit. The type and amount due are displayed on the pole display.
3. Amount received can be entered by moving the cursor to amount via selecting the **Amount** or **Previous** or **Next** keys. The change to be given is automatically updated as the received amount is entered.

4. Selection of the **Cancel** key clears all the data and moves the cursor to the Registration digits.
5. If linked to an external guest system, the guest card is presented to the keyboard / serial reader. If free, the fare indicates free. If the reader is set as an Entry/exit/guest reader, the reader mode is displayed and must be changed to guest by selection of the **Reader** key.
6. The **Sale** key only functions if the details are not required, optional or if required and all details have been entered. The sale key results in activation of the exit latch, opening of the till if the entry is not free and printing of a slip(s) if auto print is set in the PC printer set-up. The exit is logged (date/time, operator, PC, vehicle details, fare).
7. Selection of the **Print** key prints a slip.



---

SCS\_PPos.rtf