



**HELP VERSION - 1.01.48      2005-05-23**

This help file serves the help manual to SoftWin version 3, Point Of Sale (POS) and can be access via the program be selecting help.

## Index:

[Aim](#)

[General](#)

[Configuration](#)

[Start-Up](#)

[Closing.](#)

**EDITORS**

[Menus](#)

[File](#)

[Save](#)

[Save as](#)

[Save As Live](#)

[Save Not As Live](#)

[Print](#)

[Print preview](#)

[Print setup](#)

[Close](#)

[Exit](#)

[Card.](#)

[Card Editor](#)

[POS Card](#)

[Set-up.](#)

[Set-up editor](#)

[PC I/O set-up](#)

[POS Controller Set-up](#)

[POS PC set-up](#)

[POS Printers](#)

[General Set-up](#)

[Log Fields](#)

[Date and time properties](#)

Edit functions are described in the help file [SCS\\_Editor](#)

**Vending**  
**Point Of Sale (POS)**  
**Tools.**

Vending functions are described in the help file [SCS\\_Vend](#).

[Logon/off](#)  
[Change Password](#)  
[Menu Access](#)

**View.**

[Toolbar](#)  
[Vend ToolBar](#)  
[Status Bar](#)  
[Refresh](#)  
[Find](#)  
[Find Next](#)

**Window.**

[Cascade](#)  
[Tile Horizontally](#)  
[Tile Vertically](#)

**Help.**

[Help Topic](#)  
[About](#)

# 1 AIM

The aim and goal of this document is to serve as a general help manual for the use of the Softcon program SoftWin 3, POS. More technical details are available in documents that describe the database functions, communication and installation specifics.

The document SoftWin3\_Spec lists the specifications of the program and those specifications must comply with this document and visa versa. Certain specifications may be duplicated here for completeness and clarity (e.g. priority criteria), but duplication should be limited where possible.

General development info about the program SCS\_POS is:

**Count of tasks:** 8 (plus Mux tasks and client request tasks).  
**Program language:** C++, IDL (Interface Definition Language).  
**Technology:** MFC, Multithreading, DAO, COM and RPC.  
**Program architecture:** Multiple document templates.  
**Program development:** MS Visual C++ 6.0.

# 2 GENERAL

SCS\_POS is the Point Of Sale module of the Softcon SoftWin3 range of programs and forms part of vending. Vending concepts are applicable and these are not duplicated in this document (see [SCS\\_Vend](#)).

SCS\_POS can be installed and run on many PCs as required and requires a link to the program SCS\_Server that interfaces to the system databases.

SCS\_Server communicates with the databases and links via TCP communication links to client programs that can be running on the same and/or on different PCs. The program SCS\_POS is described in this document.

Operating POS is simple and logical, requiring the minimum number of keystrokes, with without a mouse.

All **transactions** are **logged** with date and time, operator reference, holder reference, item, amounts charged, discounted, etc. All **settings** are **password** protected.

A variety of **reports** are available, indicating the transactions in detail or as summary for each (or all) POS and for a selected operator (or all).

Operators must log-on before any transactions can take place, and must log-off when leaving the POS. Passwords can be set to auto expire.

Different [languages](#) are accommodated via configuration databases.

# 3 CONFIGURATION

The configuration of a POS terminal (with cash draw) is as per the diagram below.

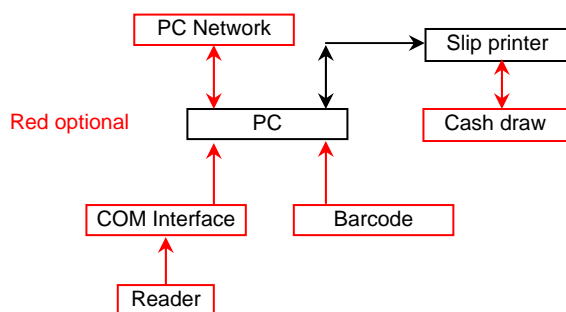

## 4 START-UP

The Softcon program SCS\_Server.exe must be running before the client program is started. SCS\_POS can be started with the following parameters:

- /start** Starts and links to the previous server selected, with the password shut down with.
- /start:???** Starts and links to server running on PC ???, with the password shut down with. ??? is the network name or IP address of the PC.

These parameters can be viewed in help about or by starting the program with the parameter */?*

The Softcon program SCS\_Server.exe can be started with the following parameters:

- /audit** All database editing is logged to the daily audit file c:\softwin3\audit\auyymmdd.mdb.
- /language:???** Selects language ???. Requires the appropriate language fields in the configuration databases. See [language](#) in SCS\_Edit.hlp set-up.
- /start** Starts with the password shut down with.

These parameters can be viewed in help about by right clicking on the dialog name bar (blue section on the top) or by starting the program with the parameter */?*

When SCS\_POS starts running the following occurs:

- Initialises the server for communication.
- Creates the client RAM.
- Starts COM port tasks.

The SW is protected by [security keys](#) security that is stored in the mux card. Test and demo versions are available.

## 5 CLOSING

- Stops COM port tasks.
- Frees the client RAM.
- Stops the check connection task.
- Closes the client RAM temporary database.
- Sends "bye" to the server application.
- Stops RPC service.

# 6 MENUS

## 6.1 FILE MENU

### 6.1.1 Save.

Saves the data in the current active window. This function is only active when the active window data can be saved, and the data is saved to the current data source.

### 6.1.2 Save as.

Saves the data in the current active window to a new file name. This function is only active when the active window data can be saved. The file location, name and type is requested.

### 6.1.3 Save As Live

Should data on display change as a result of database changes by other programs, the data on display is automatically updated when the display has been saved as live.

### 6.1.4 Save Not As Live

Displays saved not as live, display data contained in the databases when the display is opened or after refresh (select F5 key). Changes to databases by other programs are not updated on the current display.

### 6.1.5 Print. Ctrl+P

When in certain menus, the print option is active. In list editors, the selected lines are printed with column headers and column widths.

### 6.1.6 Print preview.

When the print option is active, the preview is active – showing a print preview for the default printer.

### 6.1.7 Print setup.

Enters the Windows printer set-up menu. See POS printers.

### 6.1.8 Close.

Closes the selected window (if password allows). This is equivalent to selecting  in the window.

### 6.1.9 Exit.

Exit the program.

# 7 CARD MENU

## 7.1 Card Editor

The card menu provides card information via [List editors](#). Lists are provided and more can be created by the user. Lists provided as default are:

- Card POS.** Displays vending data generally edited by canteen staff.

A property sheet is not provided.

### **Personal Details for Card holder**

- Surname.** Holders surname. This field is often used to enter the surname and first name.
- Employ number.** Company employment number, or "VISITOR - company name". The database for this parameter is normally set as unique (used by SCS\_POS). When not unique, set the following c:\softwin3\config\database.mdb:
  - Table "FIELDS", change "INDEX" to 0 in record "ID"=F\_CD\_EMPLOY.
  - Table "RAM\_GROUPS", remove record "ID"=8003.
  - Table "SQL\_READ", remove record "GROUP\_ID"=8003.

This data controls the access of the card. Data as the cards location is not editable and most of the data is editable via list selections. The data descriptions can be changed via set-up tables, but type should not be changed. The details of how access is granted or denied are described in the document SCS\_Card\_Access.

### **Card and Groups**

**Status** – Each card is set with a status of [Disabled](#), [Enabled](#) or [Capture](#). When the card has expired, the [expired status](#) is used and when the cards count is full, the [count full status](#) is used. Typically an expired card becomes capture.

**CARD Info** - Data in this section is editable and is not altered by the system.

- Number 1 and 2.** This number is the true number encoded in to, or on to the card or tag. In most installations, the number is equal to the card reference number. This number is only used for readers set with DB10, for other settings, the reference number is used as the card number. Readers are set to use cards 1 or 2 (e.g. MAG and PROX card). For DB10, the number of digits for number depends on the setting in the general set-up menu. For example when set to 5, 5 digits must be entered for number, with leading zeros to make up the 5 digits. The default set in the XLI files is 1, thus requiring no leading zeros.
- Expires.** The card expires on this date/time. The format is the same as above.
- Photo.** A photo can be linked to the card by entering the file name (with path). Drawing can be created with photos linked to readers, i.e. the photo of the card presented to the specific reader is displayed (see SoftDraw). The photo is linked to the card by double clicking on the photo area, which opens a list box of photos in the photo database. Select the appropriate photo by scrolling the list. Photos are of any popular file types, e.g. .bmp, .jpg, etc. The photo file name can be edited or selected.

The **Vend** page contains card related vending related data that is described in the vending manual.

# 8 SET-UP MENU

## 8.1 Set-up Editor

### 8.1.1 PC I/O SET-UP

Serial (via COM ports) and parallel (via LPT ports) interfaces can be connected to PCs, connecting card reader/writers, barcode readers, inputs (monitored inputs to the systems) and outputs (controlled outputs) to the system. For serial COM devices, the bit per second (**Baud**), **DataBits**, **Parity**, **StopBits** and **Flow** is set via list selections. The **Application** (SoftWin3 program) and **PC** where the programs runs are selected from lists. The **Source** selects the type of function the I/O data is referenced and is selected from one of the following:

<b>Bar Code</b>	Serial data from item reader - POS, asset track.
<b>Barrier Entry</b>	Output to entry barrier PPOS.
<b>Barrier Exit</b>	Output to exit barrier - PPOS.
<b>Card</b>	Serial data from card reader - card edit.
<b>M2M Controller</b>	Serial data to/from controller.
<b>Park Entry</b>	Serial data from entry reader – PPOS.
<b>Park Entry/Exit</b>	Serial data from entry/exit reader – PPOS.
<b>Park Exit</b>	Serial data from exit reader – PPOS..
<b>Payment</b>	Serial data to pay display –POS, PPOS.
<b>Screen</b>	Serial data to screen display – POS, PPOS.

**Type** selects the PC interface (COM1 to COM8, LPT1 to LPT8). Softcon serial interfaces have 3 outputs and parallel interfaces have 8 outputs, the appropriate output of an interface is selected via the **Port** number (1 to 3 for serial and 1 to 8 for parallel) for the item (see item set-up).

**LPT\_Address** base settings vary on certain PCs. When using a LPT device, the address must be set to match the PC setting in: Settings\ Control Panel\ System\ Hardware\ Device Manager\ Ports LPT?\ Properties\ Resources.

### 8.1.2 POS CONTROLLER SET-UP

The PC is linked to a virtual controller, setting the translator type to be used. The following data is to be set:

<b>Description.</b>	A descriptive name is given for easy identification.
<b>Type.</b>	The type of controller translator. Presently the only valid type is POS.

### 8.1.3 POS PC

A system can consist of more than one PC, with controllers being tied to any PC in the system. PC's interconnect via a PC network (e.g. an Ethernet coax cable). Each PC is allocated a unique number. The **Name** is the PC network name. If only one PC is used, the name can be set as **Localhost**, selecting the local PC.

When **Card select** and **Employ select** are checked, POS and visitor capture can point to the card database by entering the card reference number or the employee numbers respectively. When not checked, the card can only be selected via a serial reader connected to the PC.

**POS Vender** selects the vender that used by the PC.

**MAG R/W** sets the serial reader/programmer type connected to the PC for finding cards in a card or POS menu, or for edit card numbers. The type is selected from the COM reader settings (see SCS\_Client).

**Master DT** sets the PC from which time/date is synchronised. See [Date/time properties](#).

### 8.1.4 POS PRINTERS

Sets the printers in the system and allocates the **Windows Name** of the printer, the PC (POS) that prints on that printer and the number of **Slip Copies** the printer on POS must print on a sale. Additional slips can be printed by selecting the print button after a sale has been completed.

The POS printer automatically prints the operator name and the take-on and cash-up amounts when

cash-up is selected.

The format of the cash slip and cash-up print are defined in ASCII files in the Softwin3\templet directory. These text files are edited with the windows Word or NotePad edits and contain stings and commands, for example the POS\_Cashup.txt contains:

```
Date:      @@22
Company:   @@21
User:      @@31
-----
PAID:      @@33
FREE:      @@32
-----
Take ON:   @@34
Cash UP:   @@35
```

The file POS\_Description.txt lists the command that can be used and lists the files used (see shipped files):

```
@ @20 - Company name
@ @21 - Card holder employ number
@ @22 - Transaction data/time
@ @23 - Card holder name
@ @24 - Item quantity
@ @25 - Item code
@ @26 - Item name
@ @27 - Item subsidy
@ @28 - Item price
@ @29 - Total subsidy
@ @30 - Total price
@ @31 - Card holder payment subsidy
@ @32 - Card holder payment value
@ @33 - Card holder subsidy remain
@ @34 - Card holder value remain
@ @35 - Item token
@ @36 - Total token
@ @37 - Card holder payment token
@ @38 - Card holder token remain
@ @39 - Cash due
@ @40 - Cash tendered
@ @41 - Cash change due
@ @42 - Cash given
@ @43 - Take ON amount
@ @44 - Cash UP amount
@ @45 - Current operator name
```

All files in folder C:\Softwin3\Templet:

```
LineFeed.txt      - end of printing.
POS_Open_Till.txt - open draw, if it is necessary.
POS_CashUP.txt    - Print Cash UP.
POS_TakeON.txt    - Print Take ON.
```

Sale slip (all files are printed):

```
POS_Header.txt    - Print header.
POS_Item.txt      - Print Item line.
POS_Footer.txt    - Print footer (general set-up not use cash).
POS_Footer_Cash.txt - Print footer (general set-up use cash).
```

Note that printouts use more than one file.

Printer properties are set via windows printers via the windows settings menu or via the printer set-up in the edit menu.

## 8.2 General Set-up

The parameters set via this dialog, are general to the system. Only POS related info is listed in this file (see SCS\_CLIENT for descriptions of the other data – these do not have an effect on POS and should be disabled and hidden in this application).

### Main page

**Site ID.**

Site description used on reports.

**Printer On.**

On-line printing (as events occur) is enabled to the default Windows printer.

**Password period.**

Passwords can be set to auto expire by entering period in the format yyyy-mm-dd hh:mm, for example to set monthly set 0000-01-00 00:00 or every 8 hours, set 0000-00-00 08:00.

### Cards Mask page

The **COM reader mask** sets the format of the data read from the serial reader connected to the PC.

The fields are enclosed in curly brackets { } and the number of characters are indicated with a % character. The % character could be followed by a minus (fill in the front) or plus (fill at the back) character. The ? character ignores the digit.

For example: **{%-9%F\_CD\_NUM}{%-2%F\_CD\_ISSUE}0.**

Selects 9 characters from the card number field (filled with 0 at the front), 2 characters from the issue field (filled with 0 at the front) and the fixed number 0.

On receiving data from the reader, the card is searched for using all the set fields, if not found, a card unknown event is generated with the data set in the value field, i.e. all data must match (including the fixed data).

### Vending page

See the Vending help files.

## 8.3 Log fields

The optional fields that are logged are enabled by ticking the appropriate fields in the log fields set menu. Field description lists the general events that have data in these fields. See logging in SCS\_Client for more details.

POS issue requires Z1 to Z7. **Events** are:

**Cash Add** t10 nPCref s350 xref to v0 z1cash z2value z3operator z4tendered  
z5due z6change due z7change given.

Xref is zero if cost group used.

V is cost group (0 is no cost group).

Z1 is cash to add to card or cost groups value.

Z2 is card or cost groups new value remain.

**Cash Up** t14 nVender ref s369 Xoper vcash-up z1PC.

**Take-on** t14 nVender ref s368 Xoper vtake-on z1PC.

**POS Item** t12 nItem ref s355 Xref v0 z1cost z2cost z2sub z5qty z8tokens.

## 8.4 Date and time properties

Changing the time and date of the local PC via this menu results in the change being sent to all PCs running linked Softcon SoftWin3 programs (connected to the same SCS\_Server.exe application). The changed date/time is also sent to all controllers. PCs date/times are synchronised with the PC set as the **Master DT (PC set-up)** when the applications start and every 90 minutes thereafter. When PCs connect via the distribution server, date/time is set to that of the PC set as Master DT.

Note that changing the date/time via Windows applications will not result in the immediate sending of the changes to controllers or other PCs – this will only be done when the controllers are sent a set-up, become on-line, when applications start or when the automatic periodic synchronizations occur (once an hour for controllers, 90 minutes for PCs). The Windows time/date set applications should thus not be used and should be disabled via policy editors.



# 9 POINT OF SALE (POS)

The screenshot displays the POS software interface with the following sections:

- CLIENT:** Card N (0): 1, Employ: E0001, Name: Liebenberg, Limit: 0.00, Available: 98.45, Discount Limit: 0.00, Discount Available: 0.00, Token Limit: 0, Token Available: 0. A photo of a man is displayed next to a red "BUSY !!!" indicator.
- OPERATOR:** Liebenberg, Locked, Take On: 0.00, Cash Up: 0.00.
- CLIENT ORDER:** 2005/01/28 11:58:31, Client: Liebenberg, Site ID: Emp.: E0001. The order list shows:
 

Qty	Code	Description	Token	Discount	Price
1	1	Coke	0	0.00	5.00
2	2	Burger	0	0.00	20.00
Total:			0	0.00	25.00
Card Payment:			0	0.00	25.00
Card Remain:			0	0.00	98.45
- ITEMS:** A list of items with columns for Description, Price, Group, Bar..., Dis..., and Token. Item 2 (Burger) is selected, showing a price of 10.00 and Code 2.

Buttons at the bottom include: Add (F3), Return (F4), Print Sale (F2), Cancel Order (F5), Sale !!! (F10), Add Cash (F6), Take ON (F7), Cash UP (F8), Logon/off (F9), and Exit.

A **POS** terminal or register is a PC running the SoftWin Client application.

The POS menu consists of 4 sections:

## CLIENT

The cardholder that is purchasing or ordering items is displayed by presenting a card to the reader tied to the POS. The information displayed is the **Card number** (card database reference), the **Employee** number, the holders **Name**, the credit amount currently **Available** for purchases and allowed period credit **Limit**. The **Discount** (subsidy) and **tokens** period limit and available are what is set and remaining for the card for purchases. Before an item can be selected, a cardholder must be selected by entering the card number or the employee number (if the system has been set-up to enter these selections). If a card reader is installed, the card is badged at the reader. The cardholder's linked **photo** is displayed if the system is enabled for photo display.

A cardholder can only be selected via the reader or by entering the card / employer numbers (if enabled) when not currently busy with an order. The current status is displayed as **BUSY !!!** or **Next Customer** and is changed from busy to next customer by selecting the sale or cancel buttons. While busy, reader data is ignored and card / employer number cannot be changed.

## ITEMS

A list of the items allocated to the vender linked to the POS is displayed. When busy with an order (CLIENT section has a name), items are selected by typing the code number or by clicking on the item description. When the description box at the bottom of the list is highlighted, the item can be searched for by typing in the name (list box jump to the item starting with the characters typed). Selecting the Tab key move the edit point from code to description, barcode and to the option keys. Items could be allocated barcode number (when editing the items the barcode is entered or scanned) and searched for by scanning the code. The system defaults to the last item selection column used (e.g. if selection option was set to code, new items are selected by code).

By clicking on the column header, the items are sorted by be heading, the selected sort column is indicated with the symbol. The column can also be selected by the Alt shortcut key (indicated underscored character of the column name), e.g. to order by Description, select keys Alt and D (while Alt is selected).

Columns can be sized by moving the cursor to the column border and click and drag while the  cursor displays. The column order can be changed by clicking on the column header and dragging the column to the desired position.

Right click on a column header and selecting  Properties displays the columns properties – the name, display order, bold and if visible. The order can be changed by clicking on the column and selecting the up or down keys (on the right or right click on the name and select the Move Up / Down). The name is changed by clicking on the name and click again (or right click on the name and select Rename). The column bold status is toggled by clicking on the **B** or by right click on the name and selecting Bold Font. Columns cannot be made Editable. To make columns Visible or Invisible, click on the name and move to the left (Invisible) or to the Right (Visible) by clicking on the left or right arrow keys.

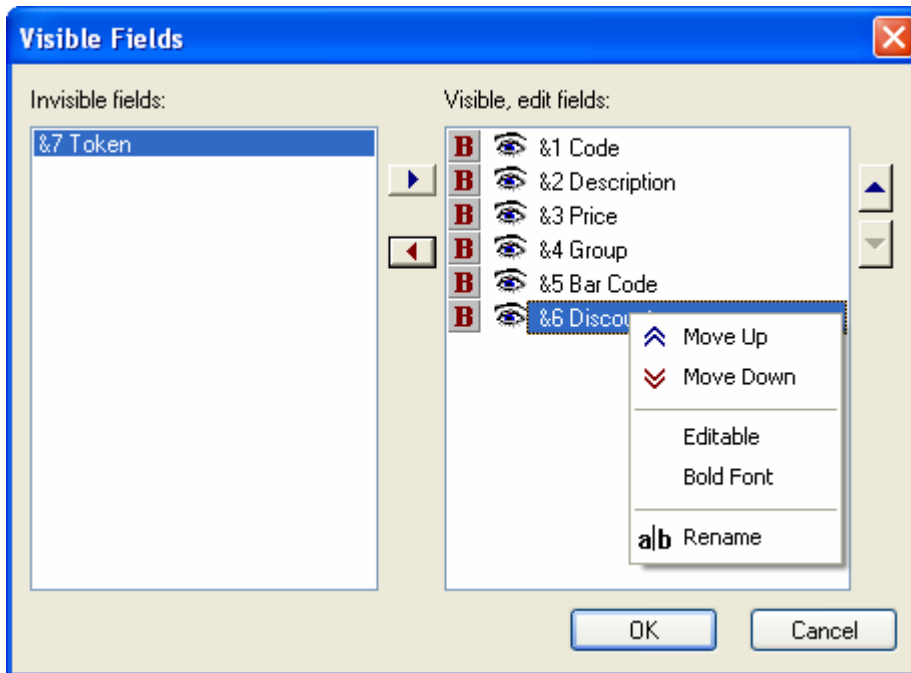



 or **Enter** or click again, transfers item selection to the current order.

 Removes an item of the current order. Select the item and click on Return.

## OPERATOR

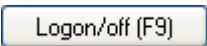
The name of logged-on operator is displayed, with the take-on and cash-up values (take-on plus cash taken) if cash is enabled in the general set-up.

 allows an operator to log-on or off.

 and  can only be selected when cash is enabled and the POS is

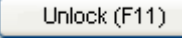
 by setting the admin mode in the PC set-up menu or via the  button (password protected).

 status is displayed when not in the admin mode and take-on and cash-up is not possible. When selecting take-on or cash-up, the cash draw is opened. On cash-up, a slip is printed with the operator information and the amounts of take-on and cash-up.

## ORDER/SALE

 2005/01/28 11:58:31 Site ID  
Client: Liebenberg Emp.: E0001

The name and employee number of the purchaser is displayed. The site id is as set in the general set-up.

Items being purchased or ordered are displayed with a total for the items.

CLIENT ORDER

2005/01/28 12:47:19		Site ID
Client: Liebenberg		Emp.: E0001

Qty	Code	Description	Token	Discount	Price
1	1	Coke	0	0.00	5.00
Total:			0	0.00	5.00
Card Payment:			0	0.00	5.00
Cash Due:					0.00
Cash Tendered:					0.00
Change Due / Given:				0.00	0.00
Card Remain:			0	0.00	93.45

**Cash** ✕

Cash Tendered:

Cash Due:

Change Due:

Given:

To Card:

**Total** is the total of the item price. **Card Payment** is the maximum that can be deducted from the card value. When the cash option is enabled in the general set-up, additional cash lines are displayed. **Cash Due** is the balance of total price less payment. **Cash Tendered** is the amount given by the client to the operator. **Change Due** is tendered less cash due. **Given** is what is cash given back to the client. Cash tendered and given is changed by selecting the  button.

The cash due is zero when the holders value exceeds the value of the order. Non-zero is when the order exceeds the holder's value. When change given is entered to a value less than due, the balance is automatically calculated to card and is added to the cardholder's value.

Cancels order and clears the order window. The client details are also cleared.

or **F10** converts the order to a sale and results in the printing of a slip(s) if set in the Vender Setup and opens the cash draw if cash is to be taken.

Prints the sale to the set slip printer. The button is only enabled after a sale.

Closes the POS menu (password protected).

Change Qty

Delete Item

---

Sale !!! (F10)

Cancel Order (F5)

Right clicking on an ordered item, displays an option box to change the quantity or delete the item. Sale or cancel options can also be selected.

# 10 TOOLS



## 10.1 PASSWORDS



Menus and items on menus are set accessible to any number of password **groups**. Any number of **users** are set to be members of users groups, i.e. a users can belong to more that one group – e.g. Peter can belong to the Control Group and to the Vending Group and has access to any menu and item these groups are set for. Adding or deleting users and groups is described below.

When logging on, a user must enter an identification name (not case sensitive) and a password (case sensitive). Passwords can be changed via the  [change password](#) selection by the user and can be set to automatically expire in the [general set-up](#) menu.

Administrators in the [menu access](#) menu set access to menus.

Groups are given access to [lists](#) by administrators opening the list, right clicking on any column name and selecting the group access option , and selecting the groups that have access to the list. When saving a list using save as, the groups can also be selected. A logged on user whose groups do not have access to a list, does not see the list in the list selection box. If a user only has access to one list in a list selection box, the list is automatically opened.

Administrators can set **items** in lists and in property sheets as invisible, visible and editable. For [lists](#), this is set by right clicking on the column name and selecting properties, moving the item to the visible box and changing to editable  or not . For [property sheets](#), administrators right click on the item (defaults to the item) or anywhere on the sheet, select the item and set the groups that have access and set editable or not.

The  option enables selection of an item of the list box, but not editing the description of the list item (combo box).  Allows for selection and editing (when the item list is a combo box).

## 10.2 Logon/off

Changed the logged on user.

## 10.3 Change Password

Changes the password of a user. The old password must be entered and the new password must be confirmed. Passwords are displayed with \*. Passwords can be set to expire automatically, see [password period](#).

## 10.4 Menu Access

Access to menus are set for user groups by operators that have access to the **Menu Access** option. Menus are made accessible by selecting the group and moving the to the appropriate menus to the accessible box on the right.

# 11 VIEW

## 11.1 Toolbar

En-disables the hotkey toolbar.

## 11.2 Vend ToolBar

En-disabled the vend tollbar.

## 11.3 Status Bar

En-disables the status bar.

## 11.4 Refresh F5

Redraws the selected window.



## 11.5 Find... Cntrl+F

Opens the find dialog box as described above.

## 11.6 Find Next F3

Find next record after Find was selected.

## 12 WINDOW

Normal Windows ordering of multiple open windows is by the selection of  **Cascade**,  **Tile Horizontally** and  **Tile Vertically**

# 13 HELP

Access to this file is by selection of the help option or selecting F1. Topic help is currently only via the help menu.

## 13.1 HELP Topic

### 13.2 ? About Softcon Client

Displays general information on the program, with parameters available when starting the program.



---

```
K configuration
# configuration
# start
```